

# SERIES-750 MS CIRCULAR THREADED COUPLING CONNECTORS

<b>INDEX</b>	<b>Page</b>
<b>MS CIRCULAR CONNECTOR</b>	<b>2</b>
<b>SHELL STYLES</b>	<b>3</b>
<b>CONNECTOR ORDERING GUIDELINES</b>	<b>4</b>
<b>TECHNICAL DATA</b>	<b>5</b>
<b>CONTACT ARRANGEMENTS : (1-3 contacts)</b>	<b>6</b>
<b>(4-6 contacts)</b>	<b>7</b>
<b>(6-8 contacts)</b>	<b>8</b>
<b>(9-14 contacts)</b>	<b>9</b>
<b>(14-24 contacts)</b>	<b>10</b>
<b>(26-104 contacts)</b>	<b>11</b>
<b>INSERT CONFIGURATIONS : (10SL-3 to 22-29 Insert Nos.)</b>	<b>12</b>
<b>(22-33 to 44-52 Insert Nos.)</b>	<b>13</b>
<b>LAYOUT DIMENSIONS</b>	<b>14</b>
<b>ACCESSORIES : (Cable Clamp, Telescopic Bushing)</b>	<b>15</b>
<b>(Protective Metal Caps MS 25042,25043)</b>	<b>16</b>
<b>(Protective Plastic Caps, Sq. Gasket)</b>	<b>17</b>
<b>(PG Adapters)</b>	<b>18</b>
<b>(Cable Clamp)</b>	<b>19</b>
<b>THRU-BULKHEAD RECEPTACLE (TBF)</b>	<b>20</b>
<b>S-750 MG BAYONET CONNECTORS</b>	<b>21</b>
<b>S-750 METRIC SERIES CONNECTORS</b>	<b>22</b>
<b>PRODUCT SAFETY</b>	<b>23</b>



## SHELL STYLES

### MS 3100E / MS 3100F

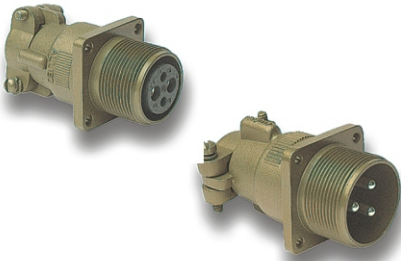

#### WALL MOUNTING RECEPTACLE WITH INTEGRAL CABLE CLAMP

MS 3100E or MS 3100F wall mounting receptacles are used to carry wires through walls or bulkheads or to provide a means of disconnection at a Bulkhead. MS 3100E or MS 3100F receptacles mate with 3106 and 3108 styles. For new equipment customers should specify MS 3100F.

### MS 3101E / 3101F



#### CABLE CONNECTOR WITH INTEGRAL CABLE CLAMP

MS 3101E or MS 3101F cable connectors are used for cable extension requirements, where mounting provisions are unnecessary. MS 3101E or MS 3101F connectors mate with 3106 and 3108 styles. For new equipment customers should specify MS 3100F.

### MS 3102E / MS 3102R



#### BOX MOUNTING RECEPTACLE

MS 3102E and MS 3102R box mounting receptacles are used in junction boxes or as an integral part of equipment. These connectors are identical in construction and mate with 3106 and 3108 styles.

For new equipment customers should specify MS 3102R.

### MS 3106E / MS 3106F



#### STRAIGHT CABLE CONNECTOR WITH INTEGRAL CABLE CLAMP

MS 3106E and MS 3106F straight cable connectors mate with 3100, 3101 and 3102 styles. MS 3106F is identical to MS 3106E except for 'O' ring under the coupling nut, thus effecting a seal.

For new equipment customers should specify MS 3106F.

### MS 3108E / 3108F



#### 90 ° ANGLE CONNECTOR

MS 3108E 90 ° cable connectors (without "O" ring seal with cable clamp) are used where there is limited space and where wires must be brought at abrupt angles. This connector mate with 3100, 3101 and 3102 styles. MS 3108F is identical to MS 3108E except for "O" ring under the coupling nut.

# CONNECTOR ORDERING GUIDELINES

Example: **MS 3102 R 28-21 S W - GP - C&C - XX**

## PREFIX

Military Standard for E, F & R Construction

## SHELL STYLES

3100 - Wall mounting Receptacle  
 3101 - Cable Mounting Connector  
 3102 - Box / Panel Mounting Receptacle  
 3106- Cable Connector - Straight  
 3108- Cable Connector - angular

## SHELL CONSTRUCTION

E - Environment Resistance (With cable clamp for cable end connector)  
 F - Environment Resistance ( With cable clamp & "O" ring for 3106 & 3108 cable connector)  
 R - Environment Resistance ( for Receptacle 3102)

## INSERT NUMBER

Consist of Shell Size 10SL, 12S, 14S, 16S,16 18,20,22,24,28,32,36,40,44 and Contact arrangement code number of pin configuration as per JSS 50812(MIL-C-5015)  
 See Pages 6 to 11

## CONTACT TYPE

P - Male  
 S - Female

## ALTERNATE INSERT POSITION

W, X, Y or Z for alternate position depending on insert (Omit for standard position.)  
 See Pages 12 & 13

## \* SPECIAL

GP - Flash Gold Plated Contacts  
 SI - Silicon Insert  
 NI - Nickel Plated Shell (Omit for standard)  
 ENI - Electroless Nickel plated shell  
 ZCG - Cadmium Free Zinc Alloy, Plating-Green

## ACCESSORIES

C & C - Cap and Chain Assembly  
 TB - Telescoping Bushing  
 DC - Dust Cap  
 SQG - Square Gasket for Receptacle 3100, 3102  
 (Accessories are not in scope of standard supply)  
 See Pages 15 to 19

## MODIFICATION

A-30 - Crimp contacts-Silver plated  
 C-30 - Crimp contacts - Flash Gold plated- Available in select contact sizes  
 211 - Less backshell grommet & follower  
 PMC - Pre Mating Contact  
 (Modifications are not in scope of standard supply)

\* CONSULT FACTORY FOR OTHER SPECIALS AVAILABLE - EMI ADAPTORS, PG ADAPTORS (Pg. 18), WATER PROOF CABLE CLAMPS (Pg. 19), TBF (Pg. 20)

## TECHNICAL DATA

SERVICE RATING	INST	A	D	E	B	C
Test Voltage at Sea level VAC ( rms)	1000	2000	2800	3500	4500	7000
Rated Working Voltage - DC At Sea level AC ( rms)	250 200	700 500	1250 900	1750 1250	2450 1750	4200 3000
Effective Creepage - Inch ( nominal ) - mm	1/16 1.57	1/8 3.18	3/16 4.75	1/4 6.35	5/16 7.92	1 25.40
Mechanical Spacing - Inch ( nominal ) - mm	- -	1/16 1.57	1/8 3.18	3/16 4.75	1/4 6.35	5/16 7.92

CONTACT SIZE	WIRE SIZE Dia ( mm )	OD OF INSULATED WIRE		MAXIMUM TEST CURRENT Amps	RATED CURRENT Amps
		Max. ( mm )	Min. ( mm )		
16	0.80	3.30	1.63	22	13
	1.00				
	1.25				
12	1.60	4.32	2.90	41	23
	2.00				
8	2.50	6.48	4.17	73	46
	3.15				
4	4.00	9.40	6.90	135	80
	5.00				
0	6.30	13.98	10.55	245	150
	8.00				

## GENERAL SPECIFICATION

Shell Housing	Aluminium Alloy
Plating	Olive Drab Cadmium
Insulator	Polychloroprene
Contact Material	Copper Base Alloy - Silver Plated
Mating Cycle	500
Operating Temperature	- 55 ° C / + 125 ° C
Insulation Resistance	Min. 5000 Meg Ohms at 500 VDC
Current Rating	Upto 150 Amps. (Depends on Contact Arrangement )
Working Voltage	200 to 3000 VAC rms ( Depends on Contact Arrangement )
Wire Termination	Solder Type

# CONTACT ARRANGEMENTS

1

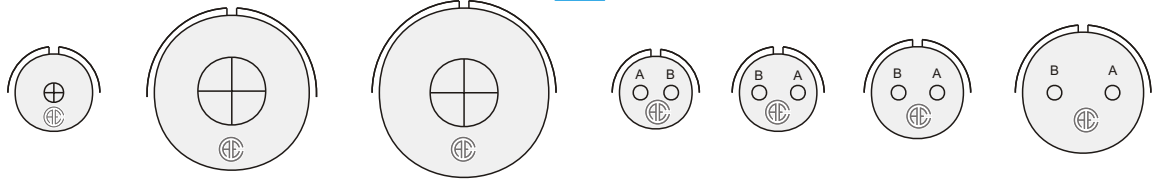

ARRANGEMENT	12 - 5	20 - 2	22 - 7	10SL - 4	12S - 3	14S - 9	16S - 4
NO. OF CONTACTS	1	1	1	2	2	2	2
CONTACT SIZE	12	0	0	16	16	16	16
SERVICE RATING	D	D	E	A	A	A	D

2

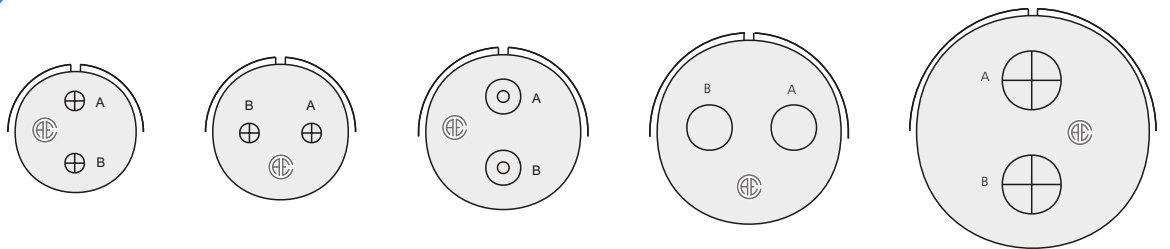

ARRANGEMENT	16 - 11	18 - 3	20 - 23	24 - 9	32 - 5
NO. OF CONTACTS	2	2	2	2	2
CONTACT SIZE	12	12	8	4	0
SERVICE RATING	A	D	A	A	D

3

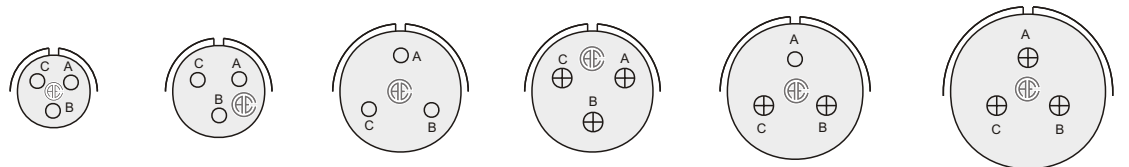

ARRANGEMENT	10SL - 3	14S - 7	16S - 5	16 - 10	18 - 5	20 - 3
NO. OF CONTACTS	3	3	3	3	3	3
CONTACT SIZE	16	16	16	12	2-12, 1-16	12
SERVICE RATING	A	A	A	A	D	D

3

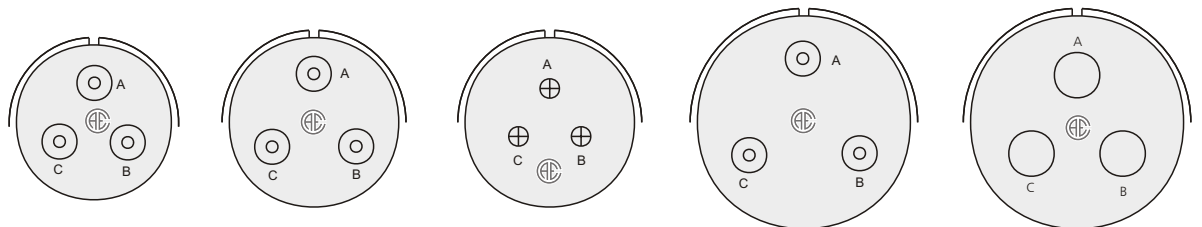
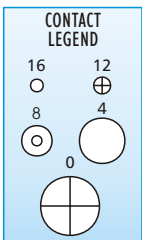

ARRANGEMENT	20 - 19	22 - 2	22 - 9	28 - 3	28 - 6
NO. OF CONTACTS	3	3	3	3	3
CONTACT SIZE	8	8	12	8	4
SERVICE RATING	A	D	E	E	D

# CONTACT ARRANGEMENTS

4

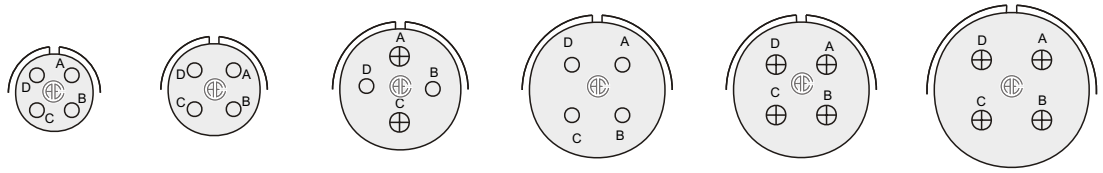

ARRANGEMENT	12SP - 10	14S - 2	16 - 9	18 - 4	18 - 10	20 - 4
NO. OF CONTACTS	4	4	4	4	4	4
CONTACT SIZE	16	16	2-12, 2-16	16	12	12
SERVICE RATING	INST.	INST.	A	D	A	D

4

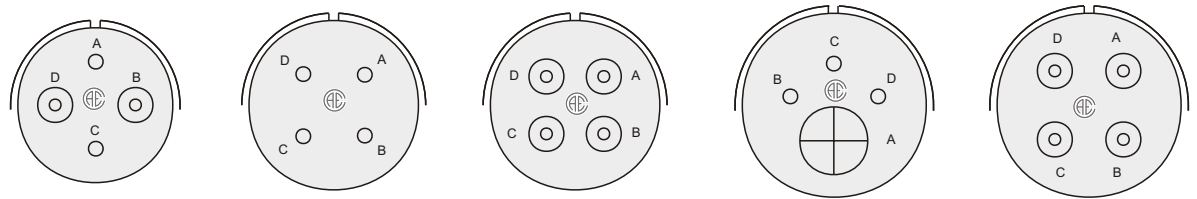

ARRANGEMENT	20 - 24	22 - 10	22 - 22	24 - 4	24 - 22
NO. OF CONTACTS	4	4	4	4	4
CONTACT SIZE	2-8, 2-16	16	8	1-0, 3-16	8
SERVICE RATING	A	E	A	D	D

4

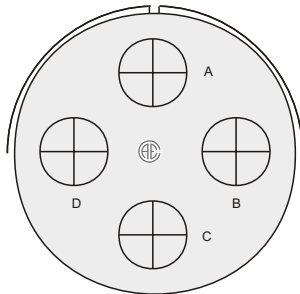
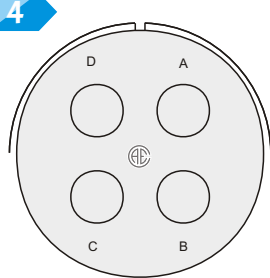

5

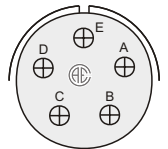
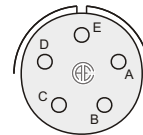
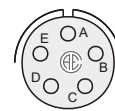

ARRANGEMENT	32 - 17	36 - 5	14S - 5	16S - 8	18 - 11
NO. OF CONTACTS	4	4	5	5	5
CONTACT SIZE	4	0	16	16	12
SERVICE RATING	D	A	INST.	A	A

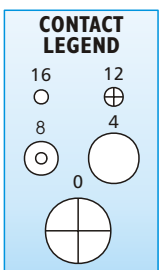

5

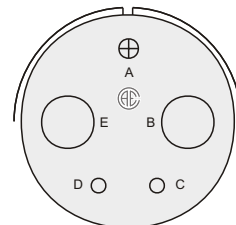
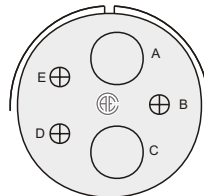
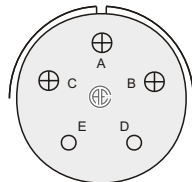
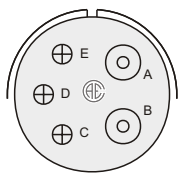

6



ARRANGEMENT	20 - 14	22 - 34	24 - 12	28 - 5	14S - 6
NO. OF CONTACTS	5	5	5	5	6
CONTACT SIZE	2-8, 3-12	3-12, 2-16	2-4, 3-12	2-4, 1-12, 2-16	16
SERVICE RATING	A	D	A	D	INST.

# CONTACT ARRANGEMENTS

6

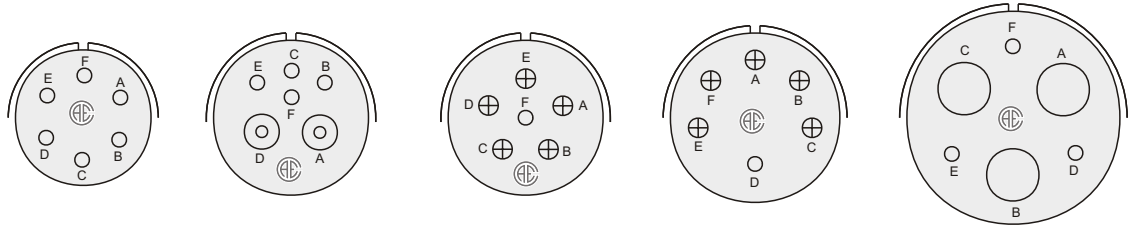

ARRANGEMENT	18 - 12	20 - 8	20 - 17	22 - 15	28 - 22
NO. OF CONTACTS	6	6	6	6	6
CONTACT SIZE	16	2-8, 4-16	5-12, 1-16	5-12, 1-16	3-4, 3-16
SERVICE RATING	A	INST.	A	D=E, ABCEF=A	D

7

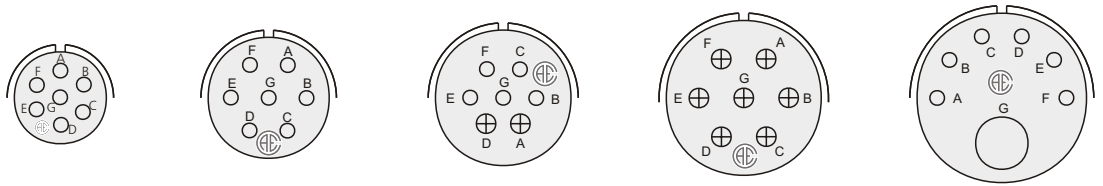

ARRANGEMENT	14SA - 61	16 - 1	18 - 9	20 - 15	22 - 29
NO. OF CONTACTS	7	7	7	7	7
CONTACT SIZE	16	16	2-12, 5-16	12	1-4, 6-16
SERVICE RATING	INST.	A	INST.	A	A

7

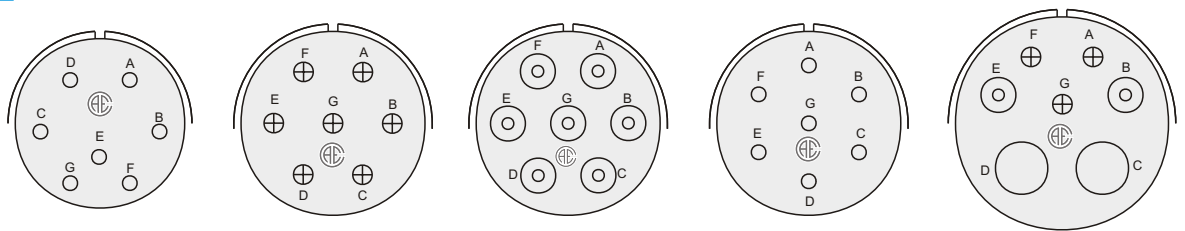

ARRANGEMENT	22 - 33	24 - 2	24 - 10	24 - 27	28 - 10
NO. OF CONTACTS	7	7	7	7	7
CONTACT SIZE	16	12	8	16	2-4, 2-8, 3-12
SERVICE RATING	ABCD=D, EFG=A	D	A	E	G=D, BAL.=A

8

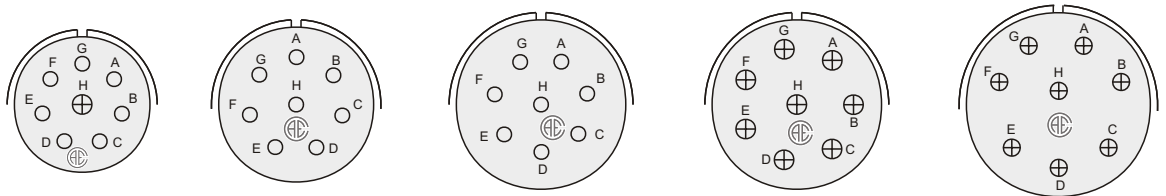
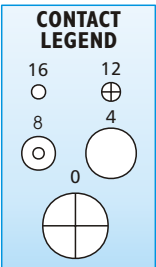

ARRANGEMENT	18 - 8	20 - 7	22 - 18	22 - 23	24 - 6
NO. OF CONTACTS	8	8	8	8	8
CONTACT SIZE	1-12, 7-16	16	16	12	12
SERVICE RATING	A	ABHG=D, CDEF=A	ABFGH=D, CDE=A	H=D, BAL.=A	A,G,H=D, BAL.=A

# CONTACT ARRANGEMENTS

9

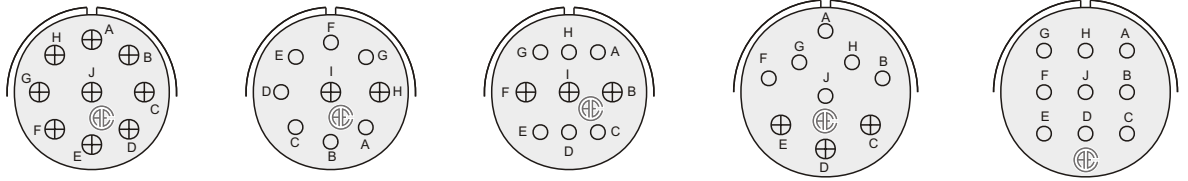

ARRANGEMENT	20L - 9	20 - 16	20 - 18	22 - 16	22 - 20
NO. OF CONTACTS	9	9	9	9	9
CONTACT SIZE	12	2-12, 7-16	3-12, 6-16	3-12, 6-16	16
SERVICE RATING	INST.	A	A	A	A

9

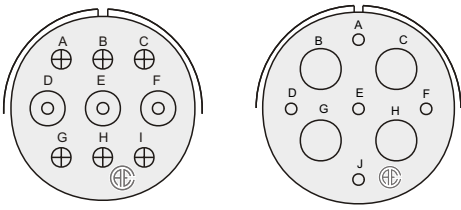

ARRANGEMENT	24 - 11	28L - 16	32 - 3	18 - 1	24 - 21
NO. OF CONTACTS	9	9	9	10	10
CONTACT SIZE	3-8, 6-12	5-16, 4-4	4-16, 2-12, 2-4, 1-0	16	1-8, 9-16
SERVICE RATING	A	A	D	BCFG=A, BAL.=INST.	D

10

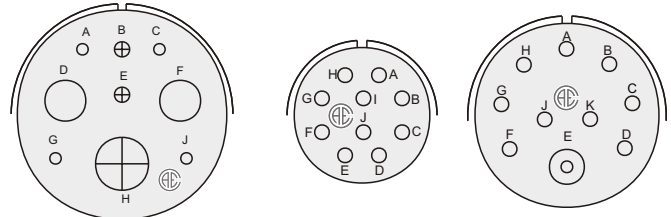

10

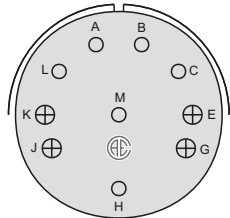

11

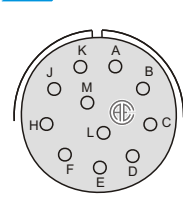

12

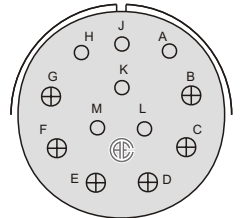
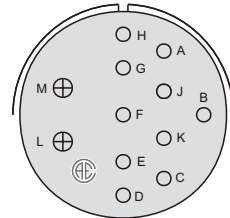
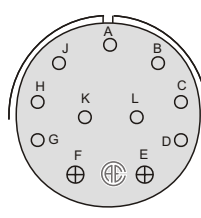

ARRANGEMENT	28 - 19	20 - 33	24 - 20	28 - 8	28 - 9
NO. OF CONTACTS	10	11	11	12	12
CONTACT SIZE	4-12, 6-16	16	9-16, 2-12	2-12, 10-16	6-12, 6-16
SERVICE RATING	HM=E, B=D, BAL.=A	A	D	LM=E, B=D, BAL.=A	D

12

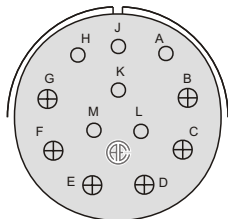

13

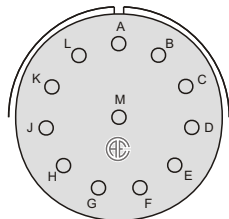

14

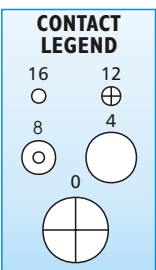
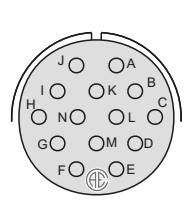
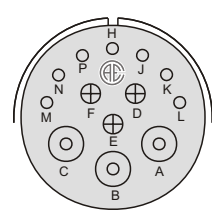

ARRANGEMENT	28 - 9	28 - 18	24L - 58	20 - 27
NO. OF CONTACTS	12	12	13	14
CONTACT SIZE	6-12, 6-16	16	3-8, 3-12, 7-16	16
SERVICE RATING	D	M=C, GHJKL=D, AB=A, BAL.=INST.	INST	A

# CONTACT ARRANGEMENTS

14

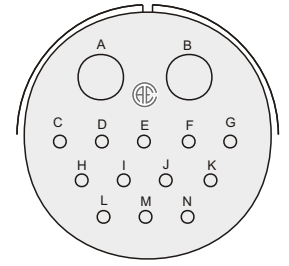
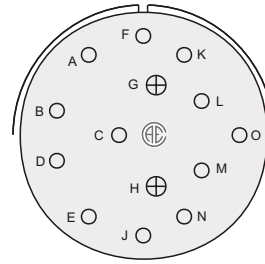
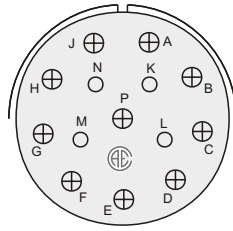
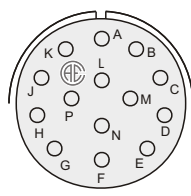

ARRANGEMENT	22 - 19	28 - 20	32 - 4	32 - 9
NO. OF CONTACTS	14	14	14	14
CONTACT SIZE	16	10-12, 4-16	2-12, 12-16	12-16, 2-4
SERVICE RATING	A	A	FJKN = A, BAL. = D	D

16

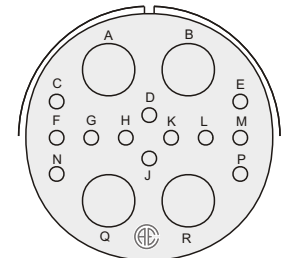
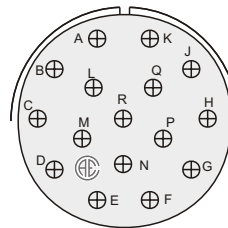
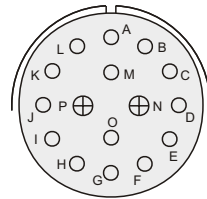
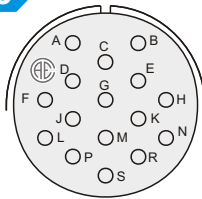

ARRANGEMENT	24 - 5	24 - 7	28L - 61	32L - 68
NO. OF CONTACTS	16	16	16	16
CONTACT SIZE	16	2-12, 14-16	12	4-4, 12-16
SERVICE RATING	A	A	A	A

16

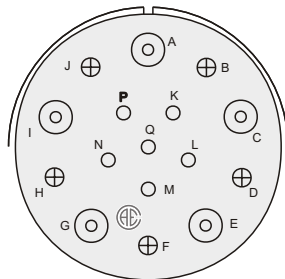

17

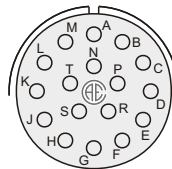

19

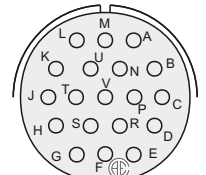
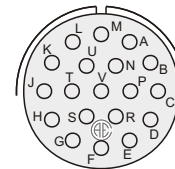

ARRANGEMENT	36 - 14	20 - 29	20L - 48	22 - 14
NO. OF CONTACTS	16	17	19	19
CONTACT SIZE	5-8, 5-12, 6-16	16	16	16
SERVICE RATING	D	A	INST.	A

## CONTACT LEGEND

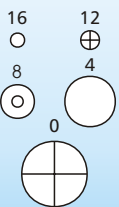

20

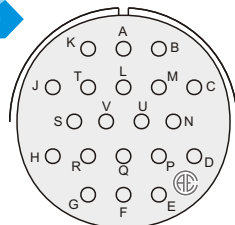

22

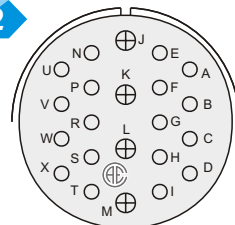

23

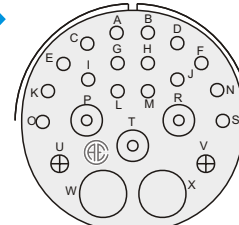

24

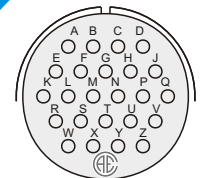

ARRANGEMENT	28 - 16	28 - 11	32 - 6	24 - 28
NO. OF CONTACTS	20	22	23	24
CONTACT SIZE	16	4-12, 18-16	2-4, 3-8, 2-12, 16-16	16
SERVICE RATING	A	A	A	INST.

# CONTACT ARRANGEMENTS

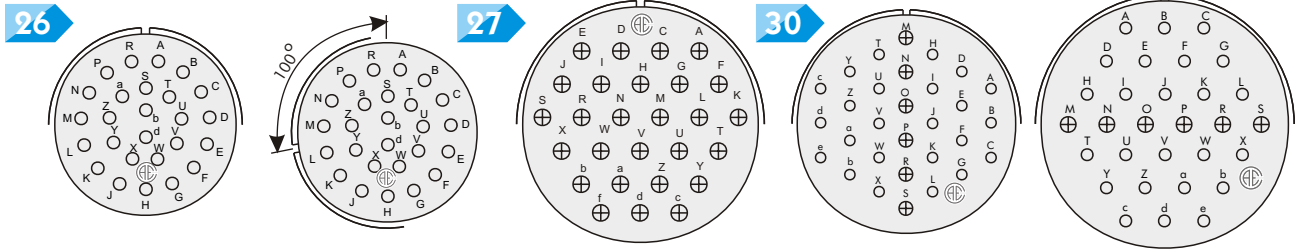

ARRANGEMENT	28 - 12	28 - 13	36L - 46	32 - 8	40 - 1
NO. OF CONTACTS	26	26	27	30	30
CONTACT SIZE	16	16	12	6-12, 24-16	6-12, 24-16
SERVICE RATING	A	A	A	A	D

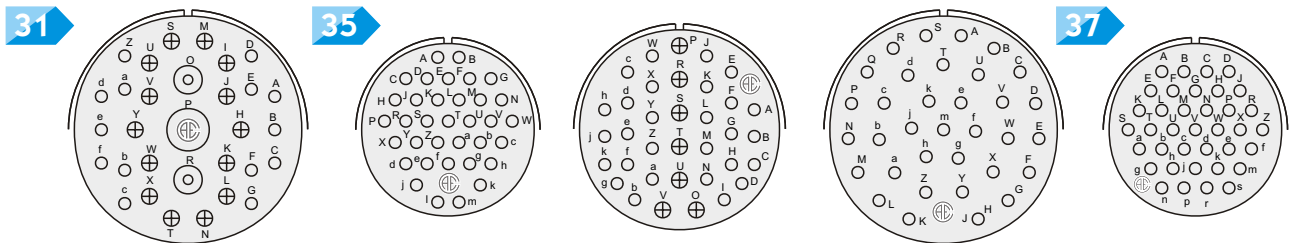

ARRANGEMENT	36 - 9	28 - 15	32 - 7	36 - 15	28 - 21
NO. OF CONTACTS	31	35	35	35	37
CONTACT SIZE	1-4, 2-8, 14-12, 14-16	16	7-12, 28-16	16	16
SERVICE RATING	A	A	ABHi=INST., BAL-A	m=D, BAL=A	A

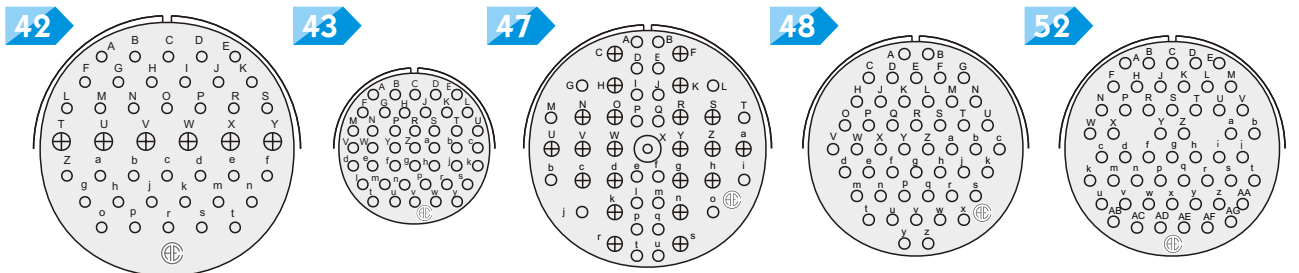

ARRANGEMENT	44 - 1	28A - 51	40 - 9	36 - 10	36L - 34
NO. OF CONTACTS	42	43	47	48	52
CONTACT SIZE	6-12, 36-16	16	1-8, 22-12, 24-16	16	16
SERVICE RATING	D	A	A	A	A

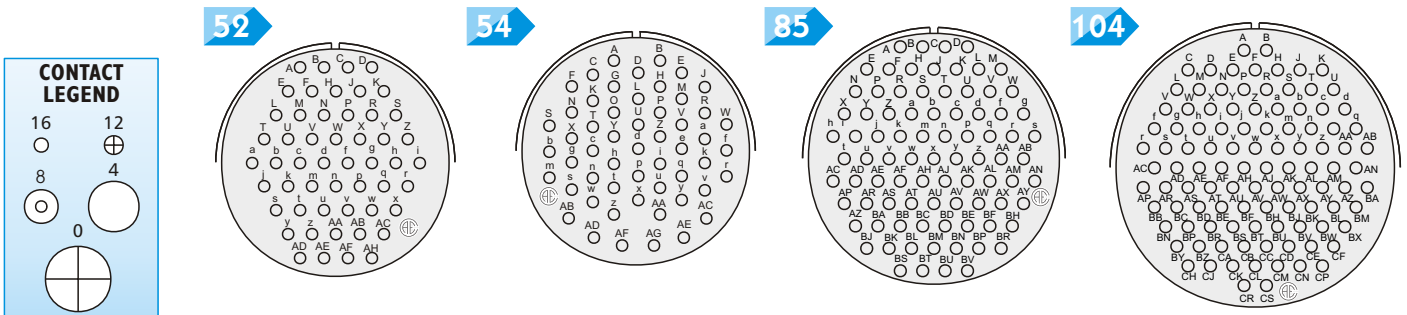





**CONTACT LEGEND**





16    12  
 ○    ⊕  
 8    4  
 ○    ⊕  
 0    ⊕

ARRANGEMENT	36 - 52	32L - 10	40 - 56	44 - 52
NO. OF CONTACTS	52	54	85	104
CONTACT SIZE	16	16	16	16
SERVICE RATING	A	A	A	A

# INSERT CONFIGURATIONS

SR. NO.	INSERT NO.	TOTAL CONTACTS	CONTACT SIZE					ALTERNATE POSITIONS (DEGREES)			
			# 0	# 4	# 8	# 12	# 16	W 	X 	Y 	Z 
1	10SL-3	3	-	-	-	-	3	-	-	-	-
2	10SL-4	2	-	-	-	-	2	-	-	-	-
3	12S-3	2	-	-	-	-	2	70	145	215	290
4	12-5 *	1	-	-	-	1	-	-	-	-	-
5	12SP-10	4	-	-	-	-	4	-	-	-	-
6	14S-1	3	-	-	-	-	3	-	-	-	-
7	14S-2	4	-	-	-	-	4	-	120	240	-
8	14S-5	5	-	-	-	-	5	-	110	-	-
9	14S-6	6	-	-	-	-	6	-	-	-	-
10	14S-7	3	-	-	-	-	3	90	180	270	-
11	14S-9	2	-	-	-	-	2	70	145	215	290
12	14SA-61	7	-	-	-	-	7	-	-	-	-
13	16S-1	7	-	-	-	-	7	80	-	-	280
14	16S-4	2	-	-	-	-	2	35	110	250	325
15	16S-5	3	-	-	-	-	3	70	145	215	290
16	16S-8	5	-	-	-	-	5	-	170	265	-
17	16-9	4	-	-	-	2	2	35	110	250	325
18	16-10	3	-	-	-	3	-	90	180	270	-
19	16-11	2	-	-	-	2	-	35	110	250	325
20	18-1	10	-	-	-	-	10	70	145	215	290
21	18-3	2	-	-	-	2	-	35	110	250	325
22	18-4	4	-	-	-	-	4	35	110	250	325
23	18-5	3	-	-	-	2	1	80	110	250	280
24	18-8	8	-	-	-	1	7	70	-	-	290
25	18-9	7	-	-	-	2	5	80	110	250	280
26	18-10	4	-	-	-	4	-	-	120	240	-
27	18-11	5	-	-	-	5	-	-	170	265	-
28	18-12	6	-	-	-	-	6	80	-	-	280
29	20-2	1	1	-	-	-	-	-	-	-	-
30	20-3	3	-	-	-	3	-	70	145	215	290
31	20-4	4	-	-	-	4	-	45	110	250	-
32	20-7	8	-	-	-	-	8	80	110	250	280
33	20-8	6	-	-	2	-	4	80	110	250	280
34	20L-9	9	-	-	-	9	-	-	110	250	-
35	20-14	5	-	-	2	3	-	80	110	250	280
36	20-15	7	-	-	-	7	-	80	-	-	280
37	20-16	9	-	-	-	2	7	80	110	250	280
38	20-17	6	-	-	-	5	1	90	180	270	-
39	20-18	9	-	-	-	3	6	35	110	250	325
40	20-19	3	-	-	3	-	-	90	180	270	-
41	20-23	2	-	-	2	-	-	35	110	250	325
42	20-24	4	-	-	2	-	2	35	110	250	325
43	20-27	14	-	-	-	-	14	35	110	250	325
44	20-29	17	-	-	-	-	17	80	-	-	280
45	20-33	11	-	-	-	-	11	-	-	-	-
46	20L-48	19	-	-	-	-	19	-	80	280	-
47	22-2	3	-	-	3	-	-	70	145	215	290
48	22-7	1	1	-	-	-	-	-	-	-	-
49	22-9	3	-	-	-	3	-	70	145	215	290
50	22-10	4	-	-	-	-	4	35	110	250	325
51	22-14	19	-	-	-	-	19	80	110	250	280
52	22-15	6	-	-	-	5	1	80	110	250	280
53	22-16	9	-	-	-	3	6	80	110	250	280
54	22-18	8	-	-	-	-	8	80	110	250	280
55	22-19	14	-	-	-	-	14	80	110	250	280
56	22-20	9	-	-	-	-	9	35	110	250	325
57	22-22	4	-	-	4	-	-	-	110	250	-
58	22-23	8	-	-	-	8	-	35	-	250	-
59	22-29	7	-	1	-	-	6	80	110	250	280

# INSERT CONFIGURATIONS

SR. NO.	INSERT NO.	TOTAL CONTACTS	CONTACT SIZE					ALTERNATE POSITIONS (DEGREES)			
			# 0	# 4	# 8	# 12	# 16	W 	X 	Y 	Z 
60	22-33	7	-	-	-	-	7	80	110	250	280
61	22-34	5	-	-	-	3	2	80	110	250	280
62	24-2	7	-	-	-	7	-	80	-	-	280
63	24-4	4	1	-	-	-	3	80	110	250	280
64	24-5	16	-	-	-	-	16	80	110	250	280
65	24-6	8	-	-	-	8	-	80	110	250	280
66	24-7	16	-	-	-	2	14	80	110	250	280
67	24-9	2	-	2	-	-	-	35	110	250	280
68	24-10	7	-	-	7	-	-	80	-	-	280
69	24-11	9	-	-	3	6	-	35	110	250	325
70	24-12	5	-	2	-	3	-	80	110	250	280
71	24-20	11	-	-	-	2	9	80	110	250	280
72	24-21	10	-	-	1	-	9	80	110	250	280
73	24-22	4	-	-	4	-	-	45	110	250	-
74	24-27	7	-	-	-	-	7	80	-	-	280
75	24-28	24	-	-	-	-	24	80	110	250	280
76	24L-58*	13	-	-	3	3	7	-	-	-	-
77	28-3	3	-	-	3	-	-	70	145	215	290
78	28-5	5	-	2	-	1	2	35	110	250	325
79	28-6	3	-	3	-	-	-	70	145	215	290
80	28-8	12	-	-	-	2	10	80	110	250	280
81	28-9	12	-	-	-	6	6	80	110	250	280
82	28-10	7	-	2	2	3	-	80	110	250	280
83	28-11	22	-	-	-	4	18	80	110	250	280
84	28-12	26	-	-	-	-	26	90	180	270	-
85	28-13	26	-	-	-	-	26	-	-	-	-
86	28-15	35	-	-	-	-	35	80	110	250	280
87	28-16	20	-	-	-	-	20	80	110	250	280
88	28L-16	9	-	4	-	-	5	-	-	-	-
89	28-18	12	-	-	-	-	12	70	145	215	290
90	28-19	10	-	-	-	4	6	80	110	250	280
91	28-20	14	-	-	-	10	4	80	110	250	280
92	28-21	37	-	-	-	-	37	80	110	250	280
93	28-22	6	-	3	-	-	3	70	145	215	290
94	28L-51	43	-	-	-	-	43	-	-	-	-
95	28L-61	16	-	-	-	16	-	-	-	-	-
96	32-3	9	1	2	-	2	4	80	110	250	280
97	32-4	14	-	-	-	2	12	80	110	250	280
98	32-5	2	2	-	-	-	-	35	110	250	325
99	32-6	23	-	2	3	2	16	80	110	250	280
100	32-7	35	-	-	-	7	28	80	125	235	280
101	32-8	30	-	-	-	6	24	80	125	235	280
102	32-9	14	-	2	-	-	12	80	110	250	280
103	32L-10	54	-	-	-	-	54	-	-	-	-
104	32-17	4	-	4	-	-	-	45	110	250	-
105	32L-68	16	-	4	-	-	12	-	-	-	-
106	36-5	4	4	-	-	-	-	-	120	240	-
107	36-9	31	-	1	2	14	14	80	125	235	280
108	36-10	48	-	-	-	-	48	80	125	235	280
109	36-14	16	-	-	5	5	6	90	180	270	-
110	36-15	35	-	-	-	-	35	60	125	245	305
111	36L-34	52	-	-	-	-	52	-	-	-	-
112	36L-46	27	-	-	-	27	-	-	-	-	-
113	36-52	52	-	-	-	-	52	72	144	216	288
114	40-1	30	-	-	-	6	24	65	130	235	300
115	40-9	47	-	-	1	22	24	65	125	225	310
116	40-56	85	-	-	-	-	85	72	144	216	288
117	44-1	42	-	-	-	6	36	65	125	225	310
118	44-52	104	-	-	-	-	104	-	-	-	-

\* CONSULT FACTORY BEFORE ORDERING.  
SPECIAL INSERT ARRANGEMENTS ALSO AVAILABLE.

ALTERNATE POSITIONS: To avoid mis-mating of similar connectors which may be adjacently mounted, polarisation is achieved with different angular positioning of the insulator within the shell. Given here is a list of different angular positions for various contact arrangements.

# LAYOUT DIMENSIONS

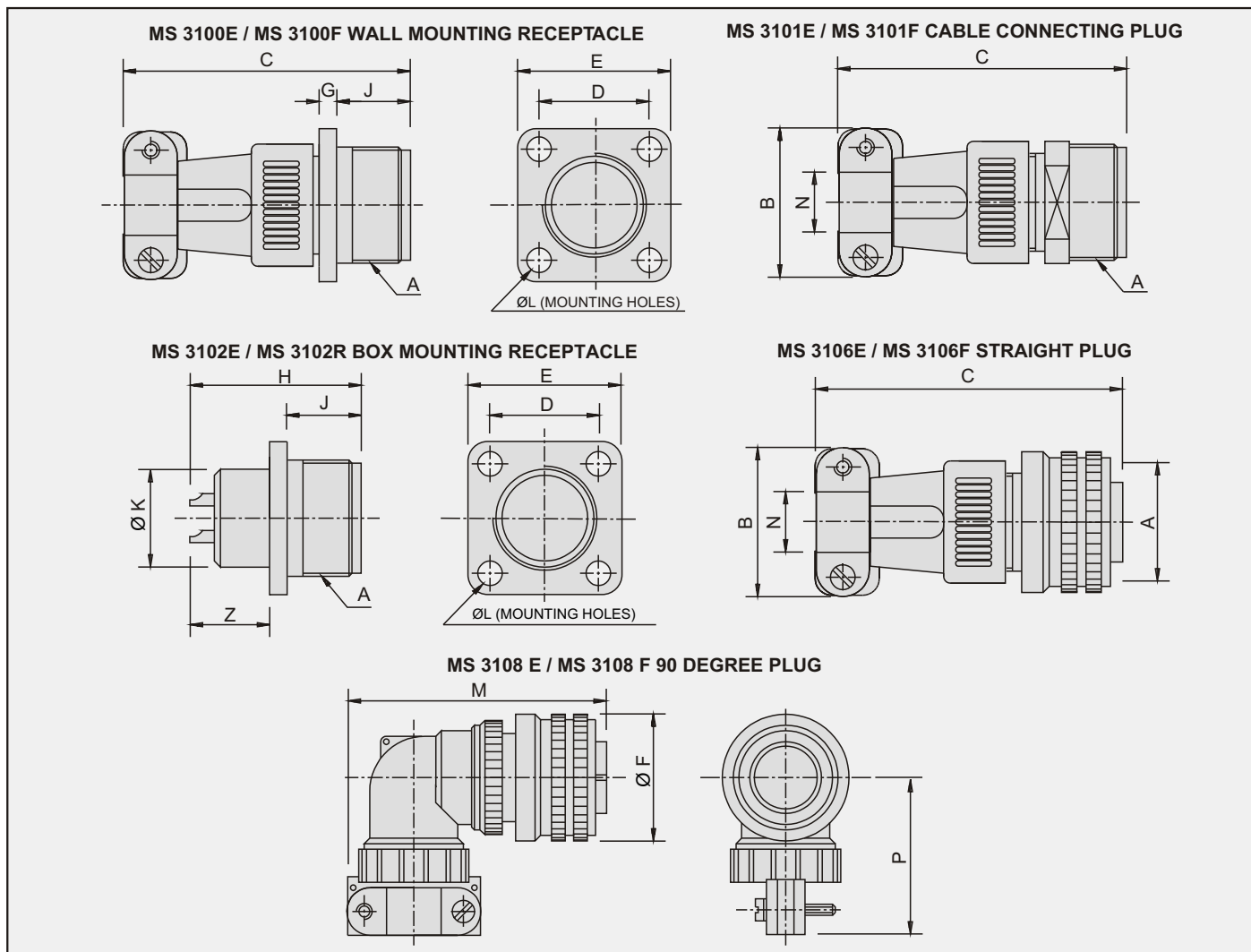

<b>44</b>	2 3/4" - 16 UN	88.90	105.0	60.32	76.20	75.40	9.12	49.23	22.23	66.60	4.39	-	30.00	47.60	-	13.15 to 19.50 depending upon contact gauges and shell size.
<b>40</b>	2 1/2" - 16 UN	68.28	88.90	55.58	69.85	69.16	9.12	49.23	22.23	60.50	4.39	114.71	23.10	34.50	80.98	
<b>36</b>	2 1/4" - 16 UN	58.40	83.30	49.23	63.50	62.71	9.12	49.23	22.23	53.80	4.39	109.14	17.60	34.50	69.06	
<b>32</b>	2" - 18 UNS	52.70	77.00	44.45	57.15	56.36	9.12	49.23	22.23	47.80	4.39	106.38	15.90	31.30	65.89	
<b>28</b>	1 3/4" - 18 UNS	44.20	77.00	39.67	50.80	50.01	5.16	49.23	20.62	41.00	3.73	94.46	11.90	23.40	55.58	
<b>24</b>	1 1/2" - 18 UNEF	44.20	75.40	34.92	44.45	43.65	5.16	49.23	20.62	35.10	3.73	94.46	11.90	23.40	53.98	
<b>22</b>	1 3/8" - 18 UNEF	38.10	69.85	31.75	41.28	40.48	5.16	49.23	19.05	31.80	3.05	82.55	8.90	18.50	50.80	
<b>20</b>	1 1/4" - 18 UNEF	38.10	69.85	29.36	38.10	37.31	5.16	49.23	19.05	28.80	3.05	82.55	8.90	18.50	50.00	
<b>18</b>	1 1/8" - 18 UNEF	33.00	68.25	26.97	34.93	34.14	5.16	49.23	19.05	25.40	3.05	72.24	7.30	15.50	45.24	
<b>16</b>	1" - 20 UNEF	30.50	66.70	24.61	32.54	31.75	3.96	49.23	19.05	22.30	3.05	70.60	6.50	13.80	42.88	
<b>16S</b>	1" - 20 UNEF	30.50	57.15	24.61	32.54	31.75	3.96	30.18	14.27	22.30	3.05	61.11	6.50	13.80	42.88	
<b>14S</b>	7/8" - 20 UNEF	28.00	57.15	23.01	30.18	29.36	3.96	30.18	14.27	19.00	3.05	58.72	5.00	10.70	40.49	
<b>12S</b>	3/4" - 20 UNEF	23.00	57.15	20.62	27.79	26.97	3.96	30.18	14.27	15.90	3.05	55.58	3.60	7.50	38.10	
<b>10SL</b>	5/8" - 24 UNEF	23.00	57.15	18.26	25.40	24.59	3.96	30.18	14.27	15.40	3.05	55.58	3.60	7.50	38.10	
<b>SHELL SIZE</b>	<b>A - THREADING</b>	<b>B MAX</b>	<b>C MAX</b>	<b>± 0.13 D</b>	<b>0.79 E - SQ</b>	<b>F MAX</b>	<b>G MAX</b>	<b>H MAX</b>	<b>+0.79 -0.00 J</b>	<b>0.13 K</b>	<b>+0.25 -0.13 L</b>	<b>M MAX</b>	<b>MIN</b>	<b>MAX</b>	<b>P MAX</b>	<b>Z</b>
													<b>N</b>			

NOTE : DIMENSIONS ARE SUBJECT TO CHANGE WITHOUT PRIOR INTIMATION.

ALL DIMENSIONS ARE IN mm

# ACCESSORIES

## CABLE CLAMP MS 3057 A

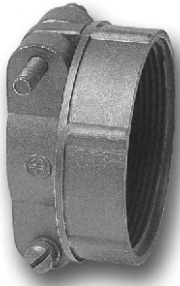

The MS 3057A cable clamp is made for cable connector and receptacles that have an endbell with external conduit threads. The double clamping action provides a balanced, positive hold on the wires and greatly reduces moisture transmission. Provision is made for safety wiring. This clamp is supplied without bushing.

FITS SHELL SIZE	PART NUMBER	ACCOMODATES MS BUSHING
10SL	MS 3057 - 4A	MS 3420 - 4
12S	MS 3057 - 4A	MS 3420 - 4
14S	MS 3057 - 6A	MS 3420 - 6
16S	MS 3057 - 8A	MS 3420 - 8
16	MS 3057 - 8A	MS 3420 - 8
18	MS 3057 - 10A	MS 3420 - 10
20	MS 3057 - 12A	MS 3420 - 12
22	MS 3057 - 12A	MS 3420 - 12
24	MS 3057 - 16A	MS 3420 - 16,12
28	MS 3057 - 16A	MS 3420 - 16,12
32	MS 3057 - 20A	MS 3420 - 20,16
36	MS 3057 - 24A	MS 3420 - 24,20
40	MS 3057 - 28A	MS 3420 - 24,20

## TELESCOPING BUSHING MS 3420



Telescoping gland bushings (used with MS 3057A cable clamp & 3100, 3101, 3106, 3108 styles) keeps dirt, oil and moisture out of endbell. Taping or wrapping wires is eliminated, since bushing protects wires going through clamp. Combinations of bushing may be used to decrease cable entry diameter to improve sealing. Material is Polychloroprene.

FITS SHELL SIZE	PART NUMBER
10SL	MS 3420 - 4
12S	MS 3420 - 4
14S	MS 3420 - 6
16S	MS 3420 - 8
16	MS 3420 - 8
18	MS 3420 - 10
20	MS 3420 - 12
22	MS 3420 - 12
24	MS 3420 - 16
28	MS 3420 - 16
32	MS 3420 - 20
36	MS 3420 - 24
40	MS 3420 - 28

# ACCESSORIES

## PROTECTIVE METAL CAPS MS 25042



### FOR 3106 AND 3108 STYLES

These external threaded metal dust caps are used to protect MS 3106 and MS 3108 styles. Material is aluminium alloy. They are supplied with sash chain.

FITS SHELL SIZE	PART NUMBER WITH SASH CHAIN
10SL	MS 25042 - 10D
12S	MS 25042 - 12D
14S	MS 25042 - 14D
16S, 16	MS 25042 - 16D
18	MS 25042 - 18D
20	MS 25042 - 20D
22	MS 25042 - 22D
24	MS 25042 - 24D
28	MS 25042 - 28D
32	MS 25042 - 32D
36	MS 25042 - 36D
40	MS 25042 - 40D
44	MS 25042 - 44D

## PROTECTIVE METAL CAPS MS 25043



### FOR 3100, 3101 AND 3102 STYLES

These internally threaded metal dust caps are used to protect MS 3100, MS 3101 and MS 3102 styles. Material is aluminium alloy. They are supplied with sash chain.

FITS SHELL SIZE	PART NUMBER WITH SASH CHAIN
10SL	MS 25043 - 10D
12S	MS 25043 - 12D
14S	MS 25043 - 14D
16S, 16	MS 25043 - 16D
18	MS 25043 - 18D
20	MS 25043 - 20D
22	MS 25043 - 22D
24	MS 25043 - 24D
28	MS 25043 - 28D
32	MS 25043 - 32D
36	MS 25043 - 36D
40	MS 25043 - 40D
44	MS 25043 - 44D

# ACCESSORIES

## PROTECTIVE PLASTIC CAPS



Protective dust caps are designed to cover the coupling end of MS connectors where there is possibility of foreign matter accumulating on the interior of the connector or to avoid damage to the threaded parts. Material is red polythylene. Plastic dust caps can be reused, but are not intended to replace the standard aluminium dust caps.

For ordering, specify 3102/3106 - shell size - DC (Dust Cap), e.g. MS 3102 - 36 - DC

## SQUARE GASKET

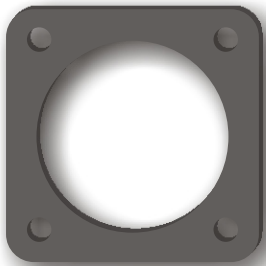

These sealing Gaskets made of Neoprene are used with flange mounted receptacles.

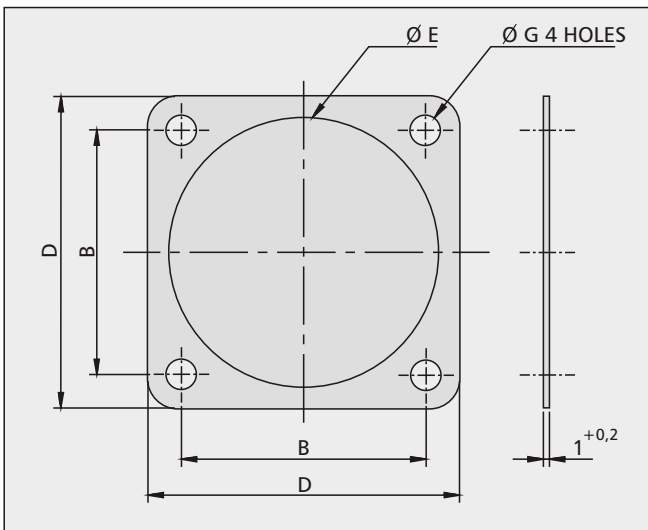

SHELL SIZE	PART NUMBER	DIMENSIONS			
		D <sup>+0,04</sup> <sub>-0,0</sub>	B <sup>±0,25</sup>	E <sup>+0,04</sup> <sub>-0,0</sub>	G <sup>±0,25</sup>
10SL	MS 02-10SL SQG	25.4	18.26	15.88	4.37
12S	MS 02-12S SQG	27.79	20.62	19.05	4.37
14S	MS 02-14.S SQG	30.17	23.01	22.22	4.37
16S	MS 02-16S SQG	32.54	24.61	25.40	4.37
18	MS 02-18 SQG	34.93	26.97	28.58	5.16
20	MS 02-20 SQG	38.10	29.36	31.75	5.16
22	MS 02-22 SQG	41.27	31.75	34.92	5.16
24	MS 02-24 SQG	44.45	34.93	38.10	5.16
28	MS 02-28 SQG	50.80	39.67	44.45	5.16
32	MS 02-32 SQG	75.15	44.45	50.80	5.56
36	MS 02-36 SQG	63.50	49.92	55.57	5.56
40	MS 02-40 SQG	69.85	55.57	61.90	5.56

DIMENSIONS ARE IN mm

# ACCESSORIES

## PG - ADAPTER FOR MS CIRCULAR CONNECTORS



SHELL SIZE	PG THREAD	Dm Ref	LENGTH
10SL	7	2,5-6.5	28
10SL	9	4-8	28
14S	11	5-10	30
16S	11	5-10	30
16	11	5-10	30
18	11	5-10	37
18	16	10-14	37
18	21	13-18	41
20	11	5-10	40
20	16	10-14	40
20	21	13-18	40
22	16	10-14	40
22	21	13-18	40
24	21	13-18	40
24	29	18-25	40
28	21	13-18	45
28	29	18-25	45

Also available PG 13.5 (6-12), PG 36 (19-32) and Metric Range of Adaptors.

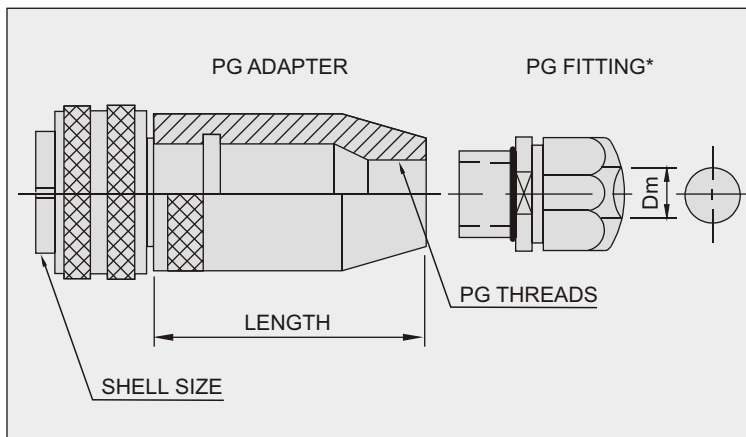

Typical Part No. =  
 MS 3106F20-17P-ADP P16+G =  
 Connector with Adapter including Hex PG Fitting  
 MS 3106F20-17P-ADP P16 =  
 Connector with Adapter without Hex PG Fitting

## PG - ADAPTER FOR MS CIRCULAR CONNECTORS



SHELL SIZE	PG THREAD	Dm Ref	LENGTH
10SL	7	2,5-6.5	20
10SL	9	4-8	20
14S	11	5-10	20
16S	11	5-10	20
16	11	5-10	20
18	11	5-10	20
18	16	10-14	20
20	16	10-14	20
22	16	10-18	20
24	21	13-18	20

Also available PG 13.5 (6-12), PG 36 (19-32) and Metric Range of Adaptors.

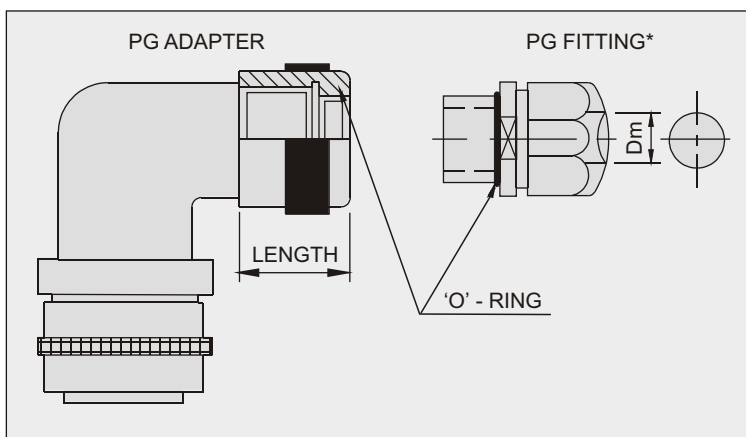

Typical Part No. =  
 MS 3108E/A20-16P-ADP P16 =  
 Connector with Adapter & with Hex PG Fitting  
 MS 3108E/A20-16S- P16 + G =  
 Connector with Adapter including Hex PG Fitting

\* CONSULT FACTORY BEFORE ORDERING  
 ALL DIMENSIONS ARE IN mm

# ACCESSORIES

## CABLE CLAMP MS 3057-C



Waterproof cable clamp with mechanical strain relief clamp, providing concentric clamping over a wide range of cable sizes. The metal body is manufactured from aluminium alloy, cadmium plated and olive drab passivated. Neoprene grommet with metal ferrule.

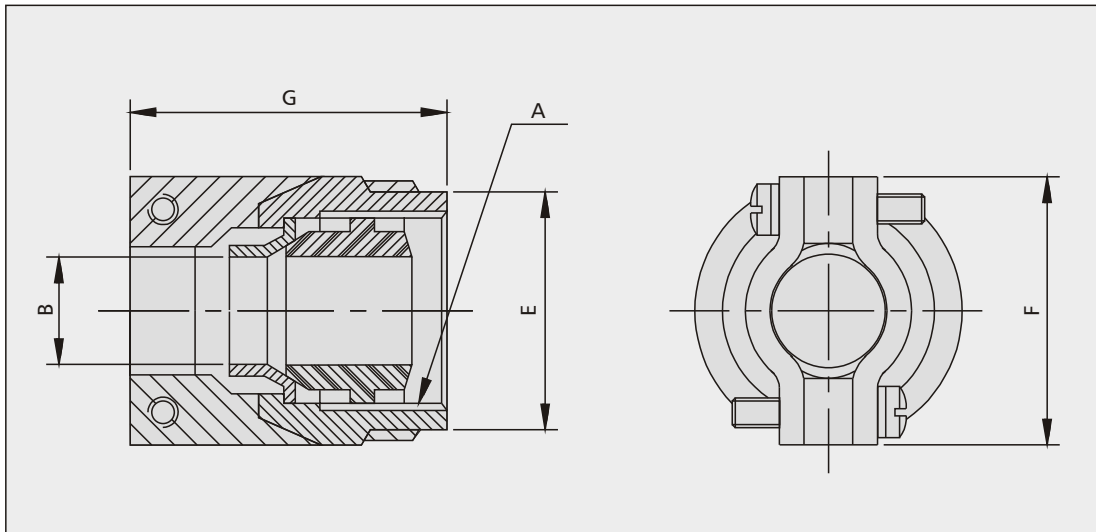

To reduce diameter B, use rubber bushing MS3420 A.

40	MS 3057 - 28C	2.250 - 16 UN	41,25	29,90	60,3	63,5	51,6
36 *	MS 3057 - 24C	2.000 - 18 UNS	35,00	23,40	53,9	57,1	51,6
32	MS 3057 - 20C	1.750 - 18 UNS	31,75	23,40	47,6	54,0	44,8
28	MS 3057 - 16C	1.4375 - 18 UNEF	23,80	15,50	39,6	42,0	38,5
24	MS 3057 - 16C	1.4375 - 18 UNEF	23,80	15,50	39,6	42,0	38,5
22	MS 3057 - 12C	1.1875 - 18 UNEF	19,00	11,30	33,3	37,3	35,7
20	MS 3057 - 12C	1.1875 - 18 UNEF	19,00	11,30	33,3	37,3	35,7
18	MS 3057 - 10C	1.000 - 20 UNEF	15,87	9,60	28,5	31,0	35,3
16	MS 3057 - 8C	0.875 - 20 UNEF	13,48	8,00	25,4	28,1	32,3
16S	MS 3057 - 8C	0.875 - 20 UNEF	13,48	8,00	25,4	28,1	32,3
14S *	MS 3057 - 6C	0.750 - 20 UNEF	11,12	5,84	22,2	25,8	32,3
10SL *	MS 3057 - 4C	0.625 - 24 UNEF	7,93	2,38	19,0	22,6	32,3
SHELL SIZE	CLAMP ORDER P/N	A THREAD CLASS 2B IN inch	OPEN	CLOSED	±0,4 E	±0,2 F	+0,5 -0 G
			B				

\* CONSULT FACTORY BEFORE ORDERING

DIMENSIONS ARE IN mm

# THRU - BULKHEAD RECEPTACLE (TBF)



TBF - Thru-bulkhead fittings have resilient insulators. It has special double-face male and female contact construction. The TBF mates with 3106 and 3108 styles.

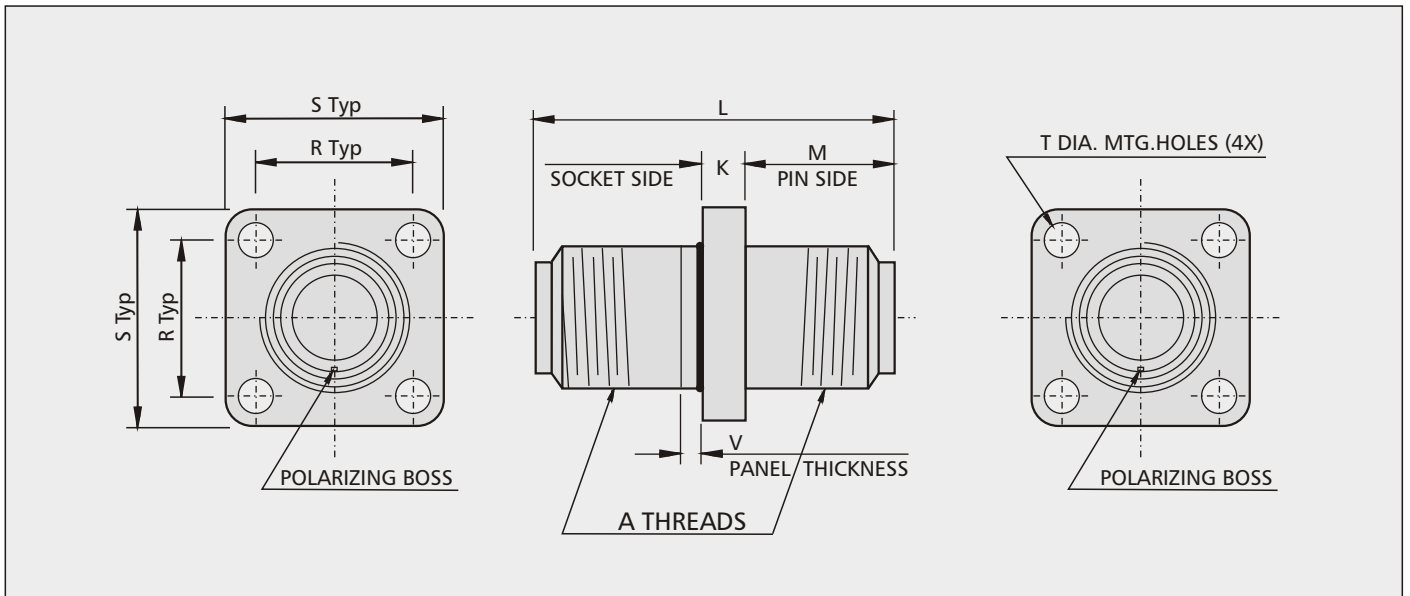

40	2 1/2" - 16 UN-2A	.203 (5.16)	2.030 (51.56)	.875 (22.22)	2.188 (55.58)	2.750 (69.85)	.173 (4.39)	.383 (9.73)
36	2 1/4" - 16 UN-2A	.203 (5.16)	2.030 (51.56)	.812 (20.62)	1.938 (49.23)	2.500 (63.50)	.173 (4.39)	.383 (9.73)
32	2" - 18 UNS-2A	.203 (5.16)	2.030 (51.56)	.812 (20.62)	1.750 (44.45)	2.250 (57.15)	.173 (4.39)	.320 (8.13)
28	1 3/4" - 18 UNS-2A	.203 (5.16)	2.030 (51.56)	.812 (20.62)	1.562 (39.67)	2.000 (50.80)	.147 (3.73)	.383 (9.73)
24	1 1/2" - 18 UNEF-2A	.203 (5.16)	2.030 (51.56)	.812 (20.62)	1.375 (34.92)	1.750 (44.45)	.147 (3.73)	.383 (9.73)
22	1 3/8" - 18 UNEF-2A	.180 (4.57)	2.030 (51.56)	.750 (19.05)	1.250 (31.75)	1.625 (41.28)	.120 (3.05)	.445 (11.30)
20	1 1/4" - 18 UNEF-2A	.180 (4.57)	2.030 (51.56)	.750 (19.05)	1.156 (29.36)	1.500 (38.10)	.120 (3.05)	.445 (11.30)
18	1 1/8" - 18 UNEF-2A	.180 (4.57)	2.030 (51.56)	.750 (19.05)	1.062 (26.97)	1.375 (34.92)	.120 (3.05)	.445 (11.30)
16S	1" - 20 UNEF-2A	.140 (3.56)	1.482 (37.64)	.562 (14.27)	.968 (24.59)	1.281 (32.54)	.120 (3.05)	.325 (8.26)
14S	7/8" - 20 UNEF-2A	.140 (3.56)	1.482 (37.64)	.562 (14.27)	.906 (23.01)	1.188 (30.18)	.120 (3.05)	.325 (8.26)
12S	3/4" - 20 UNEF-2A	.140 (3.56)	1.482 (37.64)	.562 (14.27)	.719 (18.26)	1.094 (27.79)	.120 (3.05)	.325 (8.26)
10SL	5/8" - 24 UNEF-2A	.125 (3.18)	1.482 (37.64)	.562 (14.27)	.812 (20.62)	1.000 (25.40)	.120 (3.05)	.325 (8.26)
<b>SHELL SIZE</b>	<b>A - THREADING</b>	<b>K MAX</b>	<b>L MAX</b>	$\begin{matrix} +0.031(+0.79) \\ -0.00(-0.00) \end{matrix}$ <b>M</b>	$\pm 0.005(\pm 0.13)$ <b>R</b>	$\pm 0.031(\pm 0.79)$ <b>S</b>	$\begin{matrix} +0.01(+0.25) \\ -0.005(-0.13) \end{matrix}$ <b>T</b>	<b>V MAX</b>

NOTE : All dimensions are in inch ( mm) and are for reference only. See pages 6 to 11 for contact arrangements.

## S-750 MG BAYONET



ALLIED's MG circular bayonet coupling connectors are basically MIL-C-5015 type connectors that provide superior performance. ALLIED's MG Bayonet is designed for the most difficult environment conditions. The insulators, grommets and 'O' rings are all made of high quality polychloroprene that can withstand temperature extremes from  $-55^{\circ}$  to  $+125^{\circ}$  C.

A quick 120 degree turn of the coupling nut and it audibly locks into place.

### MATERIAL AND FINISHES

ITEM	MATERIAL	FINISH
Shell	Aluminium Alloy	Olive Drab chromate coating over cadmium plating. Special Finish : (Refer to Connector Ordering Guidelines)
Insulator	Polychloroprene	--
Grommets	Polychloroprene	--
Contacts	Copper Alloy	Silver Plated

### ELECTRICAL DATA

CONTACT SIZE Awg	CONTACT RATING Max test Current A	CONTACT RESISTANCE Max contact Res. m
16S	22	6
16	22	6
12	41	3
8	73	1
4	135	0.3
0	245	0.2

# S-750 METRIC SERIES CONNECTORS

**WP/CWP/WPR/CWPR-02**



FIXED CONNECTOR WITHOUT  
BACK SHELL (SLEEVE)  
TYPE - ШР, СШР, ШРГ, СШРГ

**WP/CWP/WPR-00/00E**



FIXED CONNECTOR WITH  
STRAIGHT BACK SHELL (SLEEVE)  
TYPE - ШР, СШР, ШРГ

**WP/CWP-06**



FREE CONNECTOR WITH  
STRAIGHT SLEEVE  
TYPE - ШР, СШР

**WP/CWP-06E**



FREE CONNECTOR WITH  
STRAIGHT SLEEVE  
TYPE - ШР, СШР

**WP/CWP-08/08E**



FREE CONNECTOR WITH  
ANGULAR SLEEVE  
TYPE - ШР, СШР

**2PM/2PMR-02**

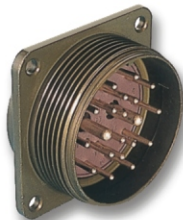

FIXED CONNECTOR  
WITHOUT SLEEVE (B)  
TYPE - 2PM, 2PMД, 2PMГ, 2PMГД

**2PM/2PMR-00/00E**



FIXED CONNECTOR WITH  
STRAIGHT SLEEVE (БПЭ, БПЭ)  
TYPE - 2PM, 2PMД, 2PMГ, 2PMГД

**2PM-06**



FREE CONNECTOR (CABLE  
MOUNTED) WITH STRAIGHT  
SLEEVE (КПЭ, КПЭ)  
TYPE - 2PM, 2PMД

**2PM-06E**



FREE CONNECTOR (CABLE  
MOUNTED) WITH STRAIGHT  
SLEEVE (КПЭ, КПЭ)  
TYPE - 2PM, 2PMД

**2PM-08**



FREE CONNECTOR (CABLE  
MOUNTED) WITH ANGULAR  
SLEEVE (КУЭ, КУЭ)  
TYPE - 2PM, 2PMД

**2PM-08E**



FREE CONNECTOR (CABLE  
MOUNTED) WITH ANGULAR  
SLEEVE (КУЭ, КУЭ)  
TYPE - 2PM, 2PMД

**2PM/2PMR-TBF**



FIXED CONNECTOR  
EQUIPMENT MOUNTING  
FEED THROUGH  
TYPE - 2PMГП, 2PMГПД

S-750 Metric Series is designed and approved to JSS-50860 Specification by LCSO. The Connectors are based on Russian design and are fully interchangeable with the GOST specification types. To suit environmental requirements of our country, the material and finish have been standardised as given here.

**SPECIFICATION** : JSS - 50860  
**SHELL** : Aluminium Alloy - O.D. Cadmium-Passivated  
**CONTACTS** : Copper Alloy - Silver Plated  
**INSERT** : Polychloroprene

*Detailed catalogue available on request.*

## PRODUCT SAFETY

These notes are intended to be used in conjunction with the Product Catalogues and Product Specifications. Products may be safely used in the applications for which they have been designed and within the specified ratings and environments. If products are exposed to conditions outside the performance ratings or specified environments they may constitute a hazard. In particular it should be noted that:-

### 1. Material Content

Circular Connectors generally use metalwork parts made of brass, aluminium, phosphor-bronze or steel, which are dependant on the particular application, may be passivated and protected with cadmium or nickel plate - in conjunction with chromated surface finishes. The insulating materials can be either natural or synthetic rubber, together with plastic or glass-filled plastic moulded parts. Contact materials vary but are usually made of Copper alloys.

### 2. Electric Shock, Burns and Fire

Hazard can occur if the product is used outside the specified parameters or if the product is damaged, wrongly wired or poorly assembled, or poorly integrated into larger equipments, or contaminated with conductive fluids. Live circuit terminations must be protected and never broken by disconnecting products.

Hot spots may be created when resistance is increased due to damage or incorrect integration particularly soldering, or loose terminations. Overheating can cause breakdown of insulation, electric shock, burns or, ultimately, fire. In the event of fire noxious and/or toxic fumes may be released and, in these circumstances, any fire involving the

product should be dealt with by personnel properly equipped. Connectors with exposed terminations or contacts should not be used on the current supply side of a circuit with exposed contacts or on an unmated product. Before making a circuit live, the product and wiring should be checked to ensure that there is no damage and no electrically conducting debris present. Circuit resistance checks should also be conducted before making the circuit live. Always ensure that connectors are assembled and wired by properly trained personnel.

### 3. Use, Transport and Storage of Products

Care must be exercised to avoid damage to any part of the products during transporting, storage or use. Abnormal transit or storage conditions and abuse during installation can give rise to damage. Products should not be used in a damaged condition.

Improper storage (particularly of damaged products) can give rise to additional hazards particularly corrosion.

### 4. Disposal of Products

Products should not be burnt.

### SAFETY RULES

- A. FOLLOW THE GUIDELINES GIVEN.**
- B. ALWAYS PROTECT LIVE CIRCUITS AND NEVER DISCONNECT A LIVE CONNECTOR.**
- C. NEVER USE A DAMAGED CONNECTOR.**
- D. NEVER BURN DISCARDED CONNECTOR.**

*Information provided in this catalogue should be used for guidelines only. Users, however, should independently evaluate the suitability of product, depending on application. Information / illustrations are subject to change without prior notice.*

### **SYNERGY TELECOM PVT LTD**

**WZ-47, SAINI CHOWK ,BUDELA VILLAGE, VIKASPURI,NEW DELHI 110018**

**Web Site:<http://www.rfconnector.in> E-mail:[ajay@rfconnector.in](mailto:ajay@rfconnector.in)**

**Fax -91 11 2853 1435**

**Phone-91 11 28533349,**