

# Synergy Telecom P Ltd.

## HT系列耐高温连接器 Series HT High Temperature Connector

HT系列耐高温连接器特别适用于石油深井测试设备和仪器中连接测试电路。

Series PT connectors are suitable to connect circuits in electronic test equipment and apparatus for petroleum deep well.

### 技术特性

#### TECHNICAL CHARACTERISTICS

电气性能 Electrical Property			
温度范围 Temperature range	达175℃ Up to +175℃	相对湿度 Relative humidity	在+40℃±20℃时,达90%~95% Up To 90%~95% , at+40±2℃
振动 Vibration	在10-2000Hz时, 加速度达15g Acceleration up to 15g at 10~2000Hz	碰撞 Collision	频率为100-2000Hz时, 加速度达50g Acceleration up to 50g at 100~2000Hz
工作电压 Working voltage	在海平面时, ≤300V 50Hz ≤300V ms,50Hz,at sea level	工作电流 Working current	0.3A

技术性能 Technical property			
接触电阻 Contact resistance	≤0.01Ω	绝缘电压 Insulation resistance	正常条件下, ≥1500MΩ; 潮湿试验后≥10MΩ; 高温试验后, ≥800MΩ ≥1500MΩ at normal, ≥10MΩ After humidity test, ≥800MΩ After high temperature test
试验电压 Test voltage	正常条件下为1200V; 潮湿试验后, 800V 1200V, at Normal, 800V, After humidity test		

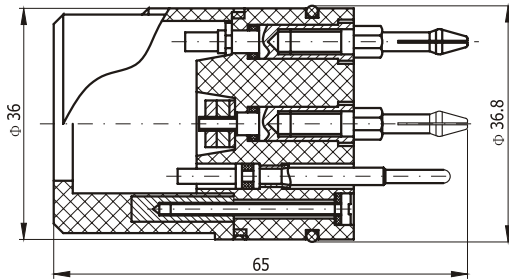

直式电缆13芯插头  
Straight Cable 13 Pins Plug



产品编码 Product NO	产品型号 Product Type	备注 Remarks
HT 41101001	HT-J13T	

直式13芯插孔插座  
Straight 13 Sockets Receptacle

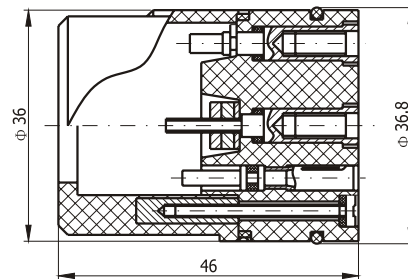

产品编码 Product NO	产品型号 Product Type	备注 Remarks
HT 40101001	HT-K13Z	

# Synergy Telecom P Ltd.

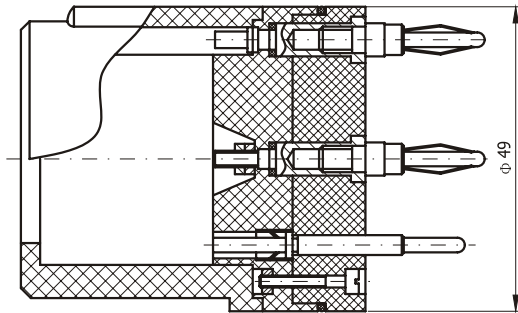

直式电缆28芯插针插头  
Straight Cable 28 Pins Plug

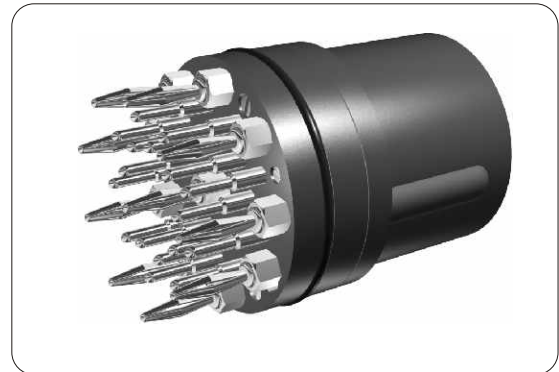

产品编码 Product NO	产品型号 Product Type	备注 Remarks
HT 41101003	HT-J28T	

直式 28 芯插孔插座  
Straight 28 Sockets Receptacle

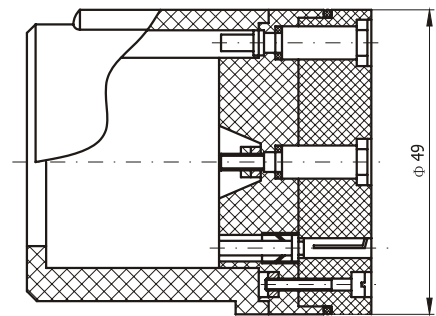

产品编码 Product NO	产品型号 Product Type	备注 Remarks
HT 40101003	HT-K28Z	